

**SIVI YAKIT FİLTRELEME, POMPALAMA
VE ISITMA İSTASYONU (FPI)**

**FUEL FILTERING,
PUMPING AND HEATING STATION (FPI)**

Fuel-oil viskozitelerine göre sınıflandırılır. Örneğin; 6 numaralı fuel-oil ağır yağ olarak bilinir ve normal ortam sıcaklığında akıcı değildir.

Endüstri brülörlerinde fuel-oilin yanma viskozitesine getirilebilmesi için filtrelenmesi, pompalanması ve ısıtılması gerekir.

Pompa kapasitesi, yakıt hattı üzerinde bulunan brülörlerin anma kapasitelerine uygun olarak tarafımızca seçilir. Yakıtın püskürtülmesi için gerekli basınç FPI istasyonundaki bu pompalardan temin edilir. Mekanik basınç püskürtmeli brülörlerde 25-30 bar; buhar parçalamalı brülörlerde 10-15 bar basınçta çalışan pompalar seçilir.

Brülör geri dönüşlerinin ana depolama veya günlük tank yerine eşanjör girişine verilerek ekonomi sağlanır. Bu sayede eşanjör yüzeyi daha küçük çıkar ve daha az yer kaplar.

Fuel-oil, eşanjörde gerçekleşen ısı transferi ile 120-135°C'ye ısıtılır ve yanma viskozitesine ulaştırılır. Böylece ideal bir yanma ve yüksek verim değerlerine ulaşılır.

FPI istasyonlarında yakıt filtreleri, pompaları ve eşanjörleri yedekli seçilebilir.

Endüstride motorin kullanılan brülörler için filtreleme ve pompalama istasyonları kullanılır.

Pumping and heating unit performs a very important function in fuel oil combustion system as it must guarantee a constant pressure and temperature of the fuel to the burner. The pumping unit is quite often disregarded but it must be considered that many combustion troubles are caused by a faulty operation of the fuel feeding unit. Problems such as fuel temperature and pressure variations, pump cavitation, too high temperatures of the heating exchanger surface which cause carbon scalings, are often found but they must be avoided.

Fuel viscosity is coded as a number depends on how liquid it is. For example heavy oil is called No : 6 and it is not liquid in the condition of room temperature.

The pump capacity is selected by burner manufacturer.

There are two types of pumping station, low pressure and high pressure. Low pressure stations are used for steam atomising burners pressure is 10-16 bar. High pressure stations are used for nozzle spill back type for fuel atomising burners pressure is 25-30 bar.

In order to have good combustion, Also we need the heat exchanger, has to heat heavy oil up to 120-135°C.

There is no need of the heat exchanger for the light oil pump station.

EŞANJÖR TİPLERİ

- Kızgın Yağ Eşanjörleri
- Buhar Eşanjörleri
- Sıcak Su Eşanjörleri
- Elektrikli Eşanjörler

HEAT EXCHANGER TYPES

- Hot Oil Exchanger
- Steam Exchanger
- Hot Water Exchanger
- Electrical Exchanger



Elektrikli Eşanjör / Electrical Heat Exchanger

FİLTRE TİPLERİ

- Buhar Yıkamalı Filtreler
- Buhar Ceketli Filtreler
- Elektrik Isıtmalı Filtreler
- Bıçaklı Filtreler

FILTER TYPES

- Steam Injected Filter
- Steam Heated Filter
- Electrical Filter
- Blade Type Filter

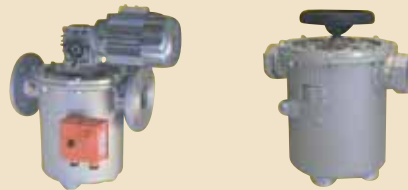

Sıvı Yakıt Filtreleri / Oil Filters

ECOSTAR YAKIT FİLTRELEME, POMPALAMA VE ISITMA İSTASYONU
ECOSTAR FUEL FILTER, PUMP AND HEAT STATION

YAKIT KAPASİTESİ [lt/h]
FUEL CAPACITY [lt/h]

YAKIT CİNSİ F : FUEL-OİL / HEAVY-OIL
FUEL TYPE M : MOTORİN / LIGHT-OIL

EŞANJÖR TİPİ K : KIZGIN YAĞLI / HOT OIL
HEAT EXCHANGER E : ELEKTRİKLİ / ELECTRICITY
TYPE S : SICAK SULU / HOT WATER
B : BUHARLI / STEAM

GRUP SAYISI T : TEK / ONE
GROUP PIECE Ç : ÇİFT-YEDEKLİ / TWO-SPARE

YEDEKLİ GRUP F : FİLTRELEME GRUBU / FİLTRE GROUP
VEYA GRUPLAR* P : POMPALAMA GRUBU / PUMP GROUP
SPARE GROUP E : EŞANJÖR GRUBU / HEAT EX. GROUP

FPI	1000	F	K	Ç	(F+P+E)	*İsteğe bağlı olarak / Can be choosen.
-----	------	---	---	---	---------	--



Motorin Pompalama Grubu
Light Oil Pumping Station



Kızgın Yağ Eşanjörü / Hot Oil Heat Exchanger



%100 Yedekli FPI (Yedekli Filtreleme, Pompalama ve Isıtma Grubu) / Pumping Group (Double System)

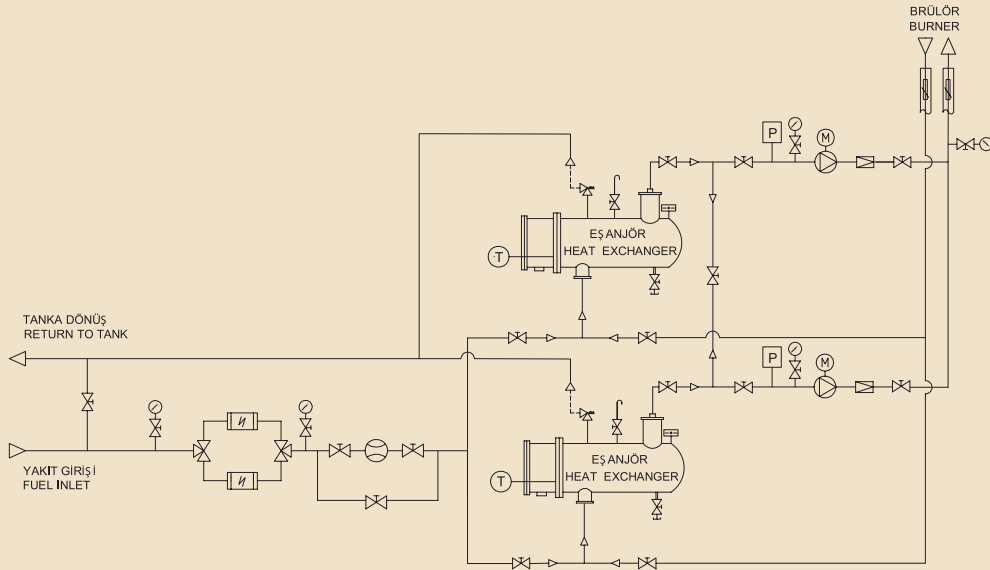

TİP TYPE	KAPASİTE CAPACITY [lt/h]	EŞANJÖR KAPASİTESİ HEAT EXCHANGER CAPACITY [kW]	POMPA MOTOR GÜCÜ PUMP MOTOR POWER [kW]	TOPLAM GÜÇ TOTAL POWER [kW]
FPI 1000	1000	30	2,2	32,2
FPI 1500	1500	45	3	48
FPI 2000	2000	60	4	64
FPI 2500	2500	75	5,5	80,5
FPI 3000	3000	90	5,5	95,5
FPI 3500	3500	105	5,5	110,5
FPI 4000	4000	120	7,5	127,5
FPI 4500	4500	135	7,5	142,5
FPI 5000	5000	150	7,5	150

• Katalogdaki verilen teknik doneler sadece bilgilendirme amaçlı olup bağlayıcı değildir; üretici firma önceden herhangi bir uyarı yapmadan değişiklik yapma hakkına sahiptir.



TERMO ISI
Sistemleri Ticaret ve Sanayi A.Ş.

Atatürk Caddesi Samibey Sokak No: 4
34843 Maltepe / İSTANBUL
Tel.: (0216) 442 93 00 (Pbx) Faks: (0216) 370 45 03
E-mail: th@termo-heat.com www.termo-heat.com